

SWEDISH • AUDIO • PASSION



CRPP-BMW1.8

User manual

BMW / MINI



CRUISE

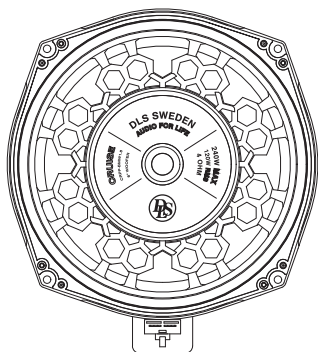

Welcome to DLS!

Thank you for buying a DLS Cruise CRPP-BMW1.8. For us, it's all about the sound experience. We care deeply about sound and construction quality. In order for your experience to be as optimal as possible, it is important that you fully read this manual, preferably before you start your installation. Keep the manual in a safe and accessible place for future reference.

Your subwoofers must be installed correctly in order to work as intended. Make sure you have all necessary tools nearby before starting and that you are completely confident in how to process. If you feel the slightest uncertainty; feel free to take the help of an experienced installer or a car audio dealer.

Warranty

This subwoofer is covered by warranty, depending on the conditions in the country where it is sold. If the subwoofer is returned for service, please include the original dated receipt with the product.

Declaration of conformity

DLS plug and play subwoofers for vehicles are manufactured in accordance with the EU directive EEC 95/54 (72/245/EEC) and are marked with the approval number. They are also marked in accordance with the WEEE-directive 2012/19/EC. The products are also produced in accordance with the EU RoHS directive 2015/863/EU.

DLS CRUISE

CRPP-BMW1.8

Content

Welcome	1
Pre installation	2
General info	2
Dismounting seat	3
Removing subwoofer	4
Mounting subwoofer	5
Remount seat	5
Specifications	6
Running-in time	6
Compatible car models	8
Product markings	10

DLS Support

For technical assistance, ask your car audio dealer where the product was sold or the distributor in your country. You can always contact the DLS Helpdesk in Sweden at e-mail: info@dls.se. Information can also be found on our WEB-site www.dls.se. We follow a policy of continuous advancement in development. For this reason, all or part of the specifications and designs may be changed without prior notice.

DLS subwoofers are engineered by DLS Sweden, a part of:

Winn Scandinavia AB

Elementvägen 15 - SE-702 27 Örebro - Sweden
Tel: +46 19 20 67 65 - E-mail: info@dls.se
www.dls.se

Designed & Sound tuned in Sweden.



Pre installation

Included products:

1pc Subwoofer

Included in box:

1pc PRY tool
1pc Manual

Disconnect Battery

Before you start the process of replacing subwoofers, disconnect and secure the negative terminal from your battery/power source. This will prevent the risk of damaging yourself or the products.

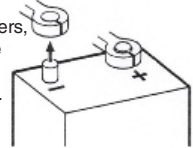

Place the disconnected terminal in a secure and isolated location away from any possible connection belonging to the battery/power source system.

General info

BMW has many different sound systems and configurations in the same year/model. This means that there are several different setups that can be installed in the same models. The subwoofer set up is very similar in the majority of the BMW models.

Before the start of the installation, take a few minutes to check how your subwoofer is placed in your car. For this reason there can be a need for different tools, such as.

- Bitscrewdriver
- Bit ratchet
- T15/20/T40 & T50 Torx bit
- Hex bit
- Philips bit
- Size 10mm & 13mm wrench
- Plastic PRY tool
- Narrow screwdriver



Remember: Use plastic PRY tool to avoid marks on the panels or damaging the plastic clips. Take your time and don't rush things. Don't use brutal force to remove a grill, trim or door panel.



Installation

Dismounting seat

HINT: There are electric connections under the seat. These need to be connected during the operation otherwise there is a huge risk that an airbag or other warning lamp lights up.

1) On some newer models, there can be a plastic cover on the seat frame. This plastic can be a bit tricky to remove. There are tabs at the back. Move the back part outwards and then slide the plastic forward.

2) The seat is fixed with 4 screws, 2 at the front and 2 at the back (6 screws in some convertible models). Normally the screws are Torx T40/T50.

Start with moving the seat up as high as it goes, then move the seat maximum back, to loosen the screws at the front of the frame.

To loosen the screws at the back, move the seat as forward as possible. Remove the screws. Save them for reassembly.

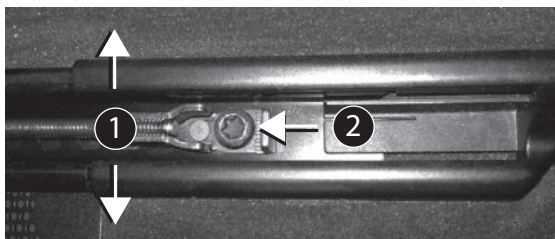

Lean the seat backwards. Be careful with all cables under the seat. Unplugging them can lead to several warning lamps in the dash panel.

HINT: Use the rear seatbelt to secure the front seat, while changing the subwoofer. Wrap the seat belt around the headrest of the front seat.

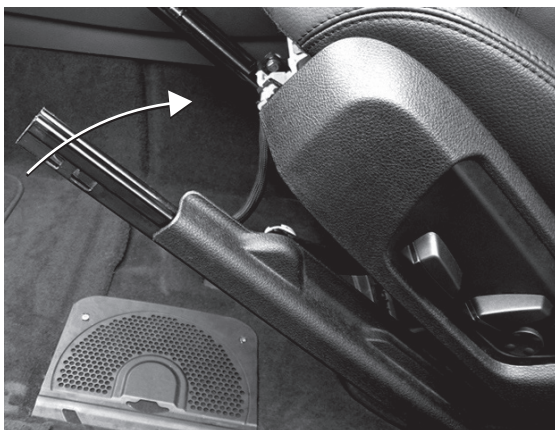



Removing subwoofer

Remove the screws that holds the plastic cover. Normally fixed with Philips screws or Torx T15/20.

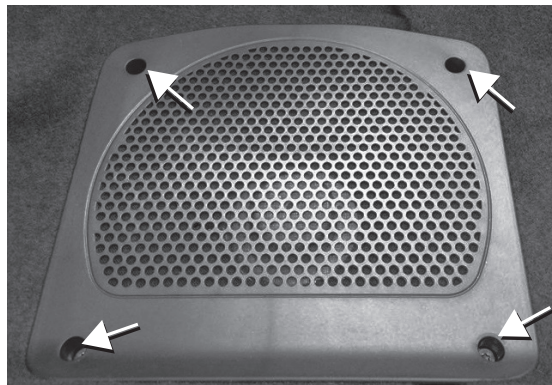

The OEM subwoofer is usually fixed with 4 Torx T15/T20 screws. If you can't see all the screws, just lift up the carpet and you will find them.

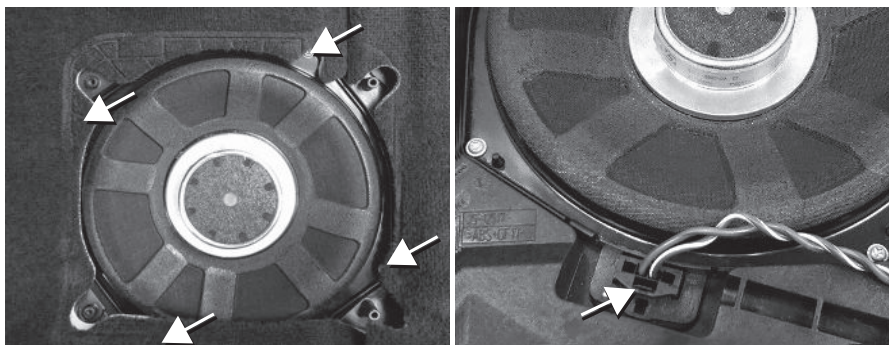

Remove the screws from the subwoofer and unplug the connector from the subwoofer. Press the tab on the connector to unplug. Sometimes it's easier to lift up the subwoofer, before unplugging the connector.

There is a gasket under the subwoofer, remove this. On older models, the gasket can be stuck on the subwoofer housing. Make sure to remove all of it. The new DLS subwoofer has a new gasket.



Mounting subwoofer

HINT: On some models, you need to remove the subwoofer housing first and mount the subwoofer in the housing, before placing the housing back under the carpet.

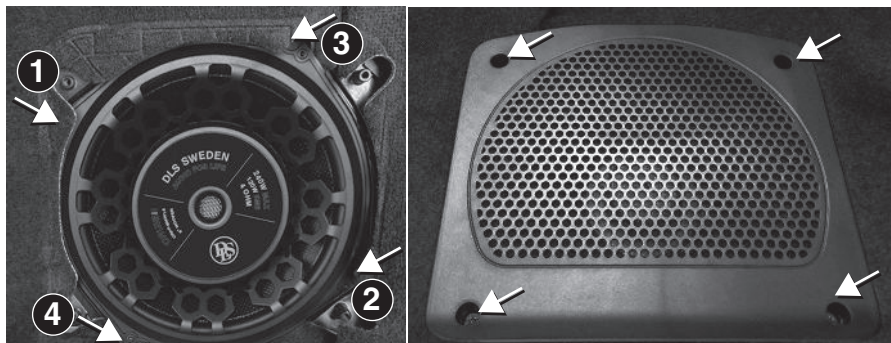

Plug the OEM connector in the DLS subwoofer. Mount the subwoofer in the housing. There is a dowel pin by the connector for lining up the subwoofer. Make sure the connector is still fixed.

Screw back the screws in a star pattern. Just fix the screws and move to the next screw. Repeat until all 4 screws are done and they are really fixed.

Place the plastic cover over the subwoofer and fix it with the OEM screws.

Remount seat

Remove the safety belt from the head rest.

Place the seat correctly over the holes. Just fix all the screws first. Now tighten them really hard, but not over tighten.

Finish with placing the plastic cover on the back of the seat chassis.

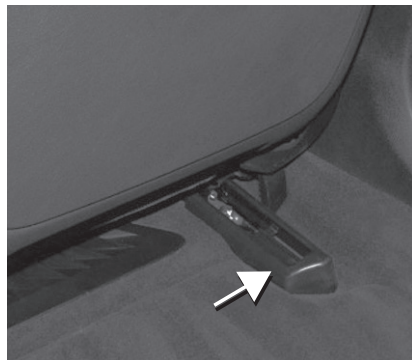
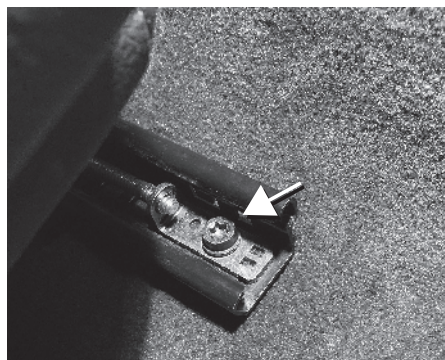



Specifications

DLS Cruise CRPP-BMW1.8 Subwoofer

Technical Specification

Size	8" / 200 mm
RMS Power	120 W
MAX Power	240 W
Voice Coil Size	2" / 50 mm
Voice Coil Material	CCA W voice coil / Kapton former
Basket	Fibreglass Reinforced ABS
Magnet	Ferrite
Cone	Fibreglass
Suspension	Rubber
Impedance	4 Ohm
Sensitivity	86 dB 1W / 1M
Freq. range	35 Hz - 500 Hz

Electro-Acoustic Parameters

Re	3.3 Ohm
Fs	45 Hz
Mms	43.5 gr
Cms	0.28
Vas	22.63 L
Qts	0.71
Qes	0.80
Qms	5.80
Bl	7.10 T.m
Sd	240 cm ²

Impedance VS Frequency

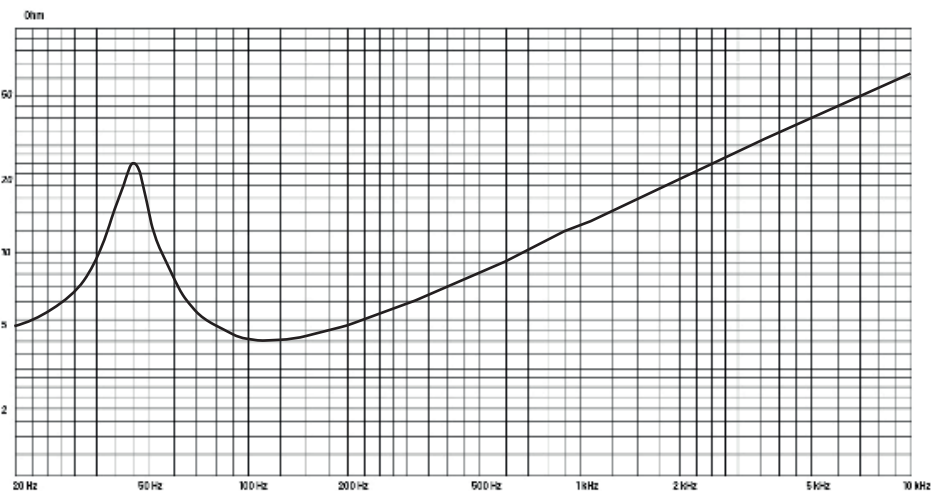

Running-in time

Allow the subwoofer to play for at least 15-20 hours in order to perform at its possibly best. This run-in can be made with bass sweep or with just music.

Start at a moderate volume and increase the volume step by step during the running in period. After the 15-20 hour run in session the performance and characteristics will be in the correct condition.

Finally, it's time to play some good music and enjoy!



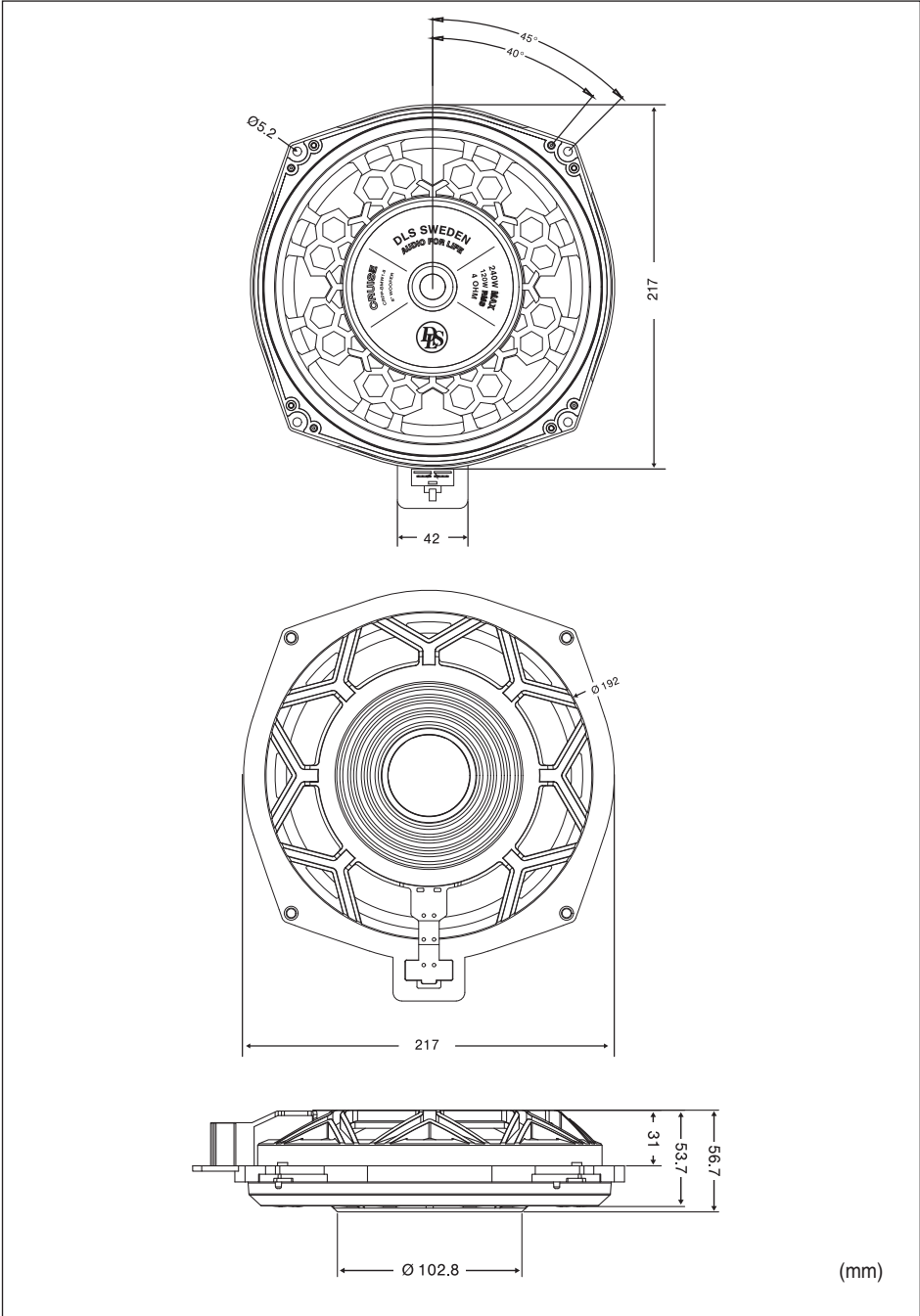

(mm)



DLS Cruise CRPP-BMW1.8 compatible car models

BMW Serie	Body	Year	Subwoofer
1-Serie	E81	2007 - 2012	Yes
1-Serie	E82	2007 - 2013	Yes
1-Serie	E87	2005 - 2011	Yes
1-Serie	E88	2008 - 2013	Yes
1-Serie	F20	2014 - 2020	Yes
1-Serie	F21	2013 - 2020	Yes
2-Serie	F22	2014 - 2020	Yes
2-Serie	F23	2014 - 2021	Yes
2-Serie	F87	2015 - 2022	Yes
2-Serie	F44	2015 - 2022	Yes
2-Serie	F45	2015 - 2022	Yes
2-Serie	F46	2015 - 2022	Yes
3-Serie	E90	2005 - 2011	Yes
3-Serie	E91	2005 - 2012	Yes
3-Serie	E92	2006 - 2013	Yes
3-Serie	E93	2007 - 2013	Yes
3-Serie	F30	2012 - 2019	Yes
3-Serie	F31	2012 - 2019	Yes
3-Serie	F34	2012 - 2021	Yes
3-Serie	F35	2012 - 2019	Yes
3-Serie	F80	2014 - 2018	Yes
4-Serie	F32	2014 - 2020	Yes
4-Serie	F33	2014 - 2020	Yes
4-Serie	F36	2014 - 2020	Yes
4-Serie	F82	2014 - 2020	Yes
4-Serie	F83	2014 - 2020	Yes
4-Serie	G22	2021 - 2023	Yes
4-Serie	G23	2021 - 2023	Yes
5-serie	E60	2003 - 2010	Yes
5-serie	E61	2003 - 2010	Yes
5-serie	F07	2009 - 2016	Yes
5-serie	F10	2010 - 2016	Yes
5-serie	F11	2011 - 2016	Yes
5-serie	G30	2017 - 2023	Yes
5-serie	G31	2017 - 2022	Yes
6-Serie	F06	2011 - 2015	Yes
6-Serie	F12	2012 - 2019	Yes
6-Serie	F13	2012 - 2019	Yes
6-Serie	G32	2018 - 2023	Yes



Serie	Body	Year	Subwoofer
7-Serie	E65	2002 - 2008	Yes
7-Serie	E66	2002 - 2008	Yes
7-Serie	E67	2001 - 2008	Yes
7-Serie	G11	2016 - 2022	Yes
7-Serie	G12	2016 - 2022	Yes
X1	E84	2009 - 2015	Yes
X1	F48	2016 - 2022	Yes
X1	F49	2016 - 2022	Yes
X3	E83	2003 - 2010	Yes
X3	F25	2011 - 2017	Yes
X4	F26	2014 - 2018	Yes
X5	E70	2007 - 2011	Yes (Only Hi-Fi & Logic 7)
X6	E71	2008 - 2014	Yes (Only Hi-Fi & Logic 7)
X6	F16	2015 - 2019	Yes (Only Base Audio, Hi-Fi & Harman Kardon)

MINI Model	Body	Year	Subwoofer
Countryman	R60	2010-2016	Yes
Paceman	R61	2013-2016	Yes
Clubman	F54	2016-2022	Yes
Hatch (5-door)	F55	2014-2019	Yes
Hatch (3-door)	F56	2014-2019	Yes
Cabrio	F57	2017-2022	Yes
Countryman	F60	2017-2021	Yes



Product markings



The crossed-out wheelee bin symbol means that the product, literature and packaging included must be taken to separate collection at the end of their working life. Do not dispose of these products as unsorted municipal waste: take them for recycling. For info on your nearest recycling point, check with your local waste authority.



This product has been granted with the CE certification mark to show that the product follows the health, safety, and environmental protection standards for products sold within the European Economic Area (EEA).



DLS products complies with the relevant provisions of the RoHS Directive for the European Union. In common with all Electrical and Electronic Equipment (EEE) the product should not be disposed of as household waste. Alternative arrangements may apply in other jurisdictions.



DLS is a global partner of the European Mobile Media Association, an organisation that focus on promoting the custom made mobile media installations to consumers.

We follow a policy of continuous advancement in development. For this reason all or part of specifications & designs may be changed without prior notice. We reserve for possible typos, factual or numeric errors that may have been printed on any products, package designs, user manuals and/or other included accessories.



CRUISE